



PT66EI-24P

Prototype board for SBC66 Netcruzer SBC Boards

----- Part of the Modtronix Netcruzer product range -----

1 Description

The PT66EI-24P is a prototype board for Netcruzer [SBC66](#) SBC(Single Board Computers) boards. The SBC66 board is plugged onto the PT66EI-24P board as a daughter board. All the SBC66 board's [signals](#) are made available on the PT66EI-24P, and prototyping space is provided. It can be mounted in the [ENC2015S-NZ](#) enclosure, and matching enclosure face plates are available for different SBC66 boards. If the SBC66 board is required to be screwed in place, the [PCBSP-143](#) 14.3mm spacer can be placed between both boards, and boards can be screwed/bolted together.

Picture 1: PT66EI-24P Board

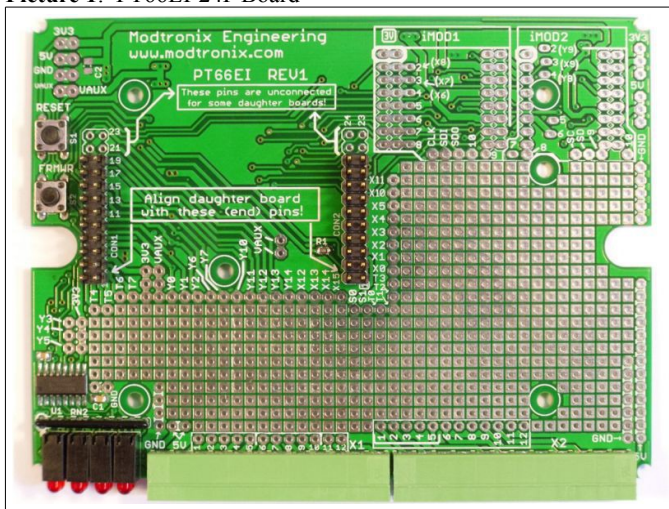

Picture 2: PT66EI-24P Board as seen from the front

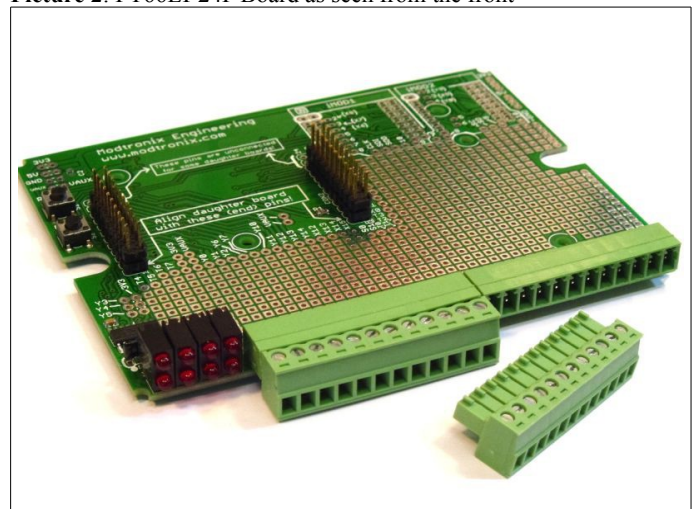

1.1 Features

- Two 12-pin, 3.81mm terminal block connectors
- Eight red LEDs
- Reset and Firmware button. If Firmware button is held in during reset (power on), board will enter bootloader mode. In this mode, firmware can be upgraded via the [Netcruzer USB Boobloader](#). For details, see [netcruzer.com/nzdoc-program](#).
- Two iMod ports for adding [iMod Modules](#). For example, can add RS-232, RS-485, 1-Wire or other iMod modules.
- Can be mounted in the [ENC2015S-NZ](#) enclosure

2 Connectors

2.1 Daughter Board Connector

The PT66EI-24P has two 2x10 pin (2.54mm = 0.1" pitch) male headers. All Netcruzer [SBC66](#) boards have two 2x10 pin female connectors, called the daughter board connector. The [SBC66](#) is mounted on the PT66EI-24P board by plugging these two connectors together. All signals are made available on the prototyping space, and are clearly labelled.

The signals on the daughter board connector of the SBC66 board are called *Netcruzer Port*. Most of them are connected to Microcontroller port pins. To assist with development, and see what Microcontroller port pin is connected to what Netcruzer Port, go to [netcruzer.com/nzdoc-sbc66-ports](#).

Table 1: Daughter Board Connector

CON1 Daughter Board Connector (mates with CON2 of SBC board!)			CON2 Daughter Board Connector (mates with CON1 of SBC board!)		
Pin	Netcruzer Port	Description	Pin	Netcruzer Port	Description
1	T5	Signal on SBC (normally a CPU port pin)	1	T1	Signal on SBC (normally CPU ICSP pin) ⁽¹⁾
2	T4	Signal on SBC (normally a CPU port pin)	2	T0	Signal on SBC (normally CPU ICSP pin) ⁽¹⁾
3	T7	Signal on SBC (normally a CPU port pin)	3	T3	Signal on SBC. Not Connected for most SBC66 boards!
4	T6	Signal on SBC (normally a CPU port pin)	4	T2	Signal on SBC (normally CPU Reset pin) ⁽²⁾
5	GND	Ground or 0V	5	S1	Signal on SBC (CPU serial peripheral pin, or N.C.) ⁽³⁾
6	3.3V	Regulated 3.3V input from SBC board	6	S0	Signal on SBC (CPU serial peripheral pin, or N.C.) ⁽³⁾
7	5V	Regulated 5V input from SBC board	7	X1	Signal on SBC (normally a CPU port pin)
8	Vin	Unregulated input voltage from SBC board	8	X0	Signal on SBC (normally a CPU port pin)
9	Y1	Signal on SBC (normally a CPU port pin)	9	X3	Signal on SBC (normally a CPU port pin)
10	Y0	Signal on SBC (normally a CPU port pin)	10	X2	Signal on SBC (normally a CPU port pin)
11	Y3	Not available, used for LEDs ⁽⁵⁾	11	X5	Signal on SBC (normally a CPU port pin)
12	Y2	Signal on SBC (normally a CPU port pin)	12	X4	Signal on SBC (normally a CPU port pin)
13	Y5	Not available, used for LEDs ⁽⁵⁾	13	X7	Signal on SBC (normally a CPU port pin)
14	Y4	Not available, used for LEDs ⁽⁵⁾	14	X6	Signal on SBC (normally a CPU port pin)
15	Y7	Signal on SBC (normally a CPU port pin)	15	X9	Signal on SBC (normally a CPU port pin)
16	Y6	Signal on SBC (normally a CPU port pin)	16	X8	Signal on SBC (normally a CPU port pin)
17	Y9	Signal on SBC (normally a CPU port pin)	17	X11	Signal on SBC (normally a CPU port pin)
18	Y8	Signal on SBC (normally a CPU port pin)	18	X10	Signal on SBC (normally a CPU port pin)
19	Y11	Signal on SBC (normally a CPU port pin)	19	SC	Signal on SBC (normally shared I2C bus of SBC) ⁽⁴⁾
20	Y10	Signal on SBC (normally a CPU port pin)	20	SD	Signal on SBC (normally shared I2C bus of SBC) ⁽⁴⁾

- ⁽¹⁾ These pins are normally connected to the in circuit serial programming (ICSP) pins of the CPU. When this is the case, they can **not** be used for general purpose IO pins!
- ⁽²⁾ This pin is normally connected to the reset pins of the CPU, which is active low. It is connected to the reset button on the PT66EI-24P board. It can **not** be used as a general purpose IO pins!
- ⁽³⁾ S0 and S1 are normally connected to a serial peripheral, or not connected at all.
- ⁽⁴⁾ SC and SD is the I2C 1 bus on all SBC66 boards.
- ⁽⁵⁾ Ports Y3, Y4 and Y5 are not available, and are used by the serial-to-parallel circuit required for driving the 8 LEDs.

Picture 3 shows the a [SBC66EC](#) board mounted on the PT66EI-24P board, and Picture 4 shows it secured with a screw and [PCBSP-143](#) spacer.

Picture 3: PT66EI-24P with Daughter Board

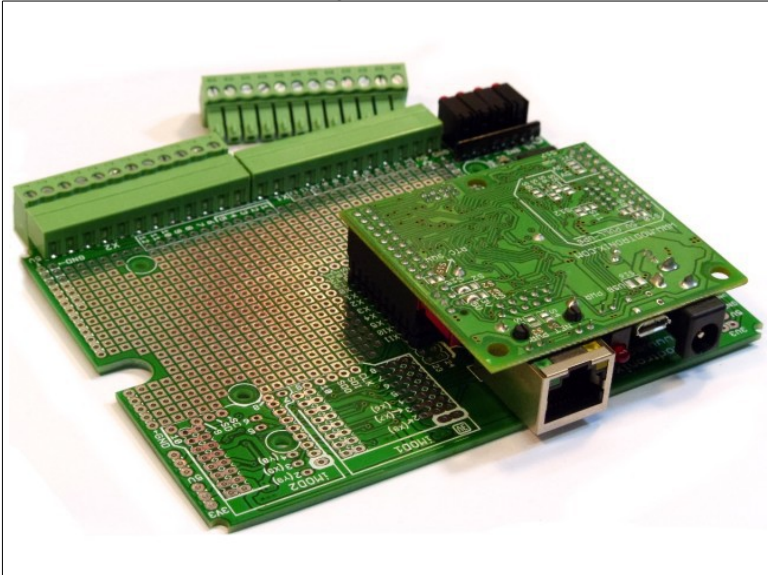

Picture 4: Boards secured via [PCBSP-143](#) PCB Spacer

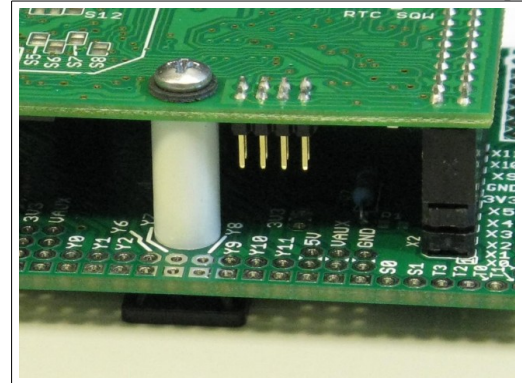

2.2 Terminal Block Connectors

The board has two 12 pin, 3.81mm pitch terminal block connectors. The pin from each connector is routed to just behind the connector, and is labelled 1 to 12 on the PCB.

3 iMod Ports

The board has two iMod ports. For a list of available iMod modules, see netcruzer.com/prod/imod.

3.1 Enabling I2C on iMod Ports

By default, the I2C bus is disabled for both iMod ports. This is because the pins used for I2C are shared with the SPI bus, and only I2C or SPI can be used for any iMod port. To enable I2C for an iMod port, two solder jumpers on the bottom of the board must be made. They are located on the bottom of the PCB, directly under the iMod port. The location of the solder jumpers are shown with yellow dots in Figure 1 on the right. To enable I2C for iMod 1, the two solder jumpers in the iMOD1 box (right on drawing) have to be made. For iMod 2, will be solder jumpers on left.

Enabling I2C for a iMod port, will connect that iMod port to the I2C 1 bus of the SBC66 board. See SBC66 board's user manual for details.

3.2 Enabling SPI on iMod Ports

By default, the SPI bus is disabled for both iMod ports. This is because the pins used for SPI are shared with the I2C bus, and only I2C or SPI can be used for any iMod port. To enable SPI for an iMod port, some solder jumpers on the bottom of the board must be made. There are two groups of jumper that have to be made.

The first group is in a box marked "iMOD 1 & 2". They select Y0, Y6 and Y7 for the SDI, SDO and CLK signals of the SPI port.

The second group routes these signals to either iMod 1 or iMod 2 (or both), and are located on the bottom of the PCB, directly under the iMod port.

The location of the solder jumpers are shown with yellow dots in Figure 2 on the right.

To enable SPI for iMod 1, the 3 solder jumpers in "iMOD 1 & 2" box, and the two solder jumpers in the iMOD1 box (under iMod port) have to be made.

Enabling SPI for an iMod port will connect the SDI, SDO and CLK signals of that iMod port to the Y0, Y6 and Y7 *Netcruzer Port* pins of the SBC66 board. These are all relocatable ports, and can be configured in code to be connected to one of the SPI ports of the Microcontroller. See SBC66 board's user manual for details.

3.3 Enabling iMod port pins

When looking at the Schematics it can be seen that some iMod ports are not enabled by default, and have to be enabled via solder jumpers. If other *Netcruzer Ports* should be used, that can be done by soldering wires between pads next to the iMod port and desired *Netcruzer Port*. See Figure 2 for location of these solder jumpers. They are in two boxes, marked "iMOD1" and "iMOD2".

For iMod port 1, iMod pin 6 can be connected to *Netcruzer Port* Y2, and pin 7 to *Netcruzer Port* Y1.

For iMod port 2, iMod pin 5 can be connected to *Netcruzer Port* X2, pin 6 can be connected to *Netcruzer Port* X3, and pin 7 to *Netcruzer Port* X4.

4 LEDs

The board has 4 LEDs that are connected to a serial-to-parallel 74HC595 chip. This enables all 8 LEDs to be controlled via only 3 CPU ports pins. The desired state of the LEDs is shifted into the shift register in code, and then latched. Once latched, the value shifted in will be displayed on the LEDs. For example code how to do this, see netcruzer.com/examples.

5 Enclosure

An enclosure, with matching face plates for different SBC66 boards is available from our site at this page: netcruzer.com/prod/enc2015s-nz

6 What port pins to use

When using this board together with a SBC66 board, the SBC66's user manual and the page at netcruzer.com/nzdoc-sbc66-ports should be used to see what *Netcruzer Ports* are available for general purpose use. Ports Y3, Y4 and Y5 are not available, and are used by the serial-to-parallel circuit for driving the 8 LEDs. The available ports depend if any iMod modules will be used, or not, and what type of iMod modules are used. If no iMod modules are used, then all available *Netcruzer Ports* listed in the SBC66 board's user manual can be used, except Y3, Y4 and Y5 that are used for the LED circuit. All *Netcruzer Ports* are clearly marked on the PCB.

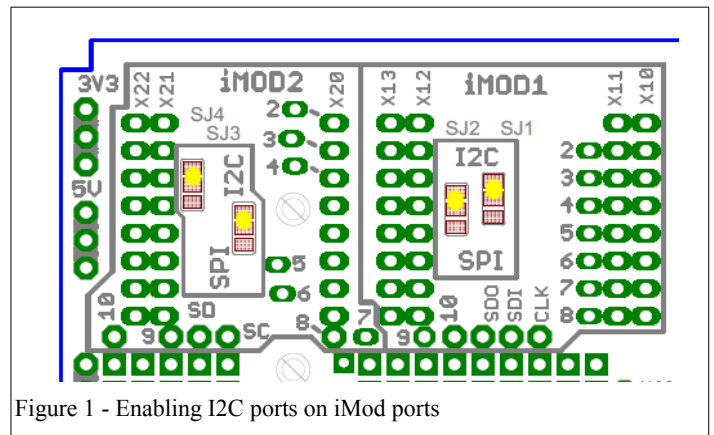

Figure 1 - Enabling I2C ports on iMod ports

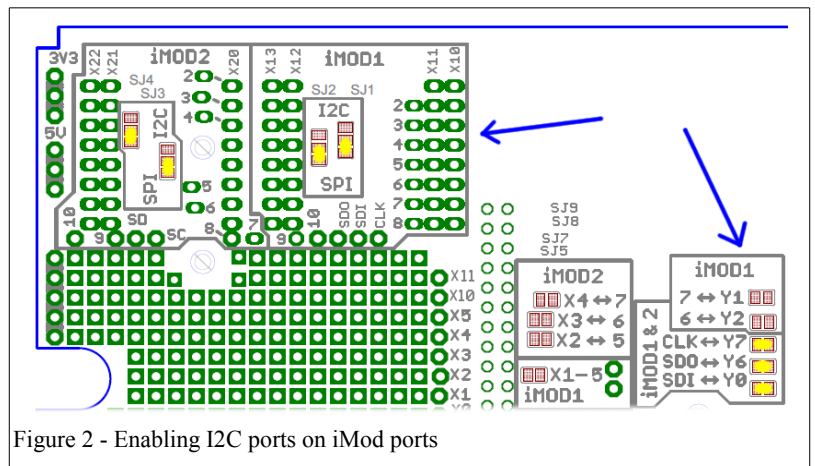

Figure 2 - Enabling I2C ports on iMod ports



Picture 5 - PT66EI-24P mounted in an enclosure

If different types of SBC66 boards will be used (for example SBC66EC with Ethernet, or SBC66ZL with ZigBee), then only *Netcruzer Ports* that are available on all SBC66 boards should be used. To do this, the table available on this page should be used: netcruzer.com/nzdoc-sbc66-ports.

6.1 Digital Inputs and Outputs

Any of the free *Netcruzer Ports* can be used as general purpose digital inputs or outputs. Refer to SBC66 board's user manual or page at netcruzer.com/nzdoc-sbc66-ports for details. For most SBC66 boards ports T4-T7, X1-X9, Y0-Y2, Y6-Y9 and Y11 can be used.

6.2 Analog Inputs

When using this board together with any SBC66 board, *Netcruzer Ports* X1 to X5, and Y0 to Y2 are available as Analog Inputs. On many SBC66 boards port X0 can also be enabled as an Analog Input by disabling the 2.5V analog reference. See SBC66 board's manual for details.

6.3 PWM outputs and peripherals

All SBC66 boards have 19 or more *relocatable ports*. These ports can be configured for special functions like PWM Outputs, UART communication ports, IR ports, SPI serial ports, External interrupts, Timer inputs and more. For details, see SBC66 board's user manual.

For example, if 9 PWM outputs are required, any of the relocatable ports can be used. Looking at the table at netcruzer.com/nzdoc-sbc66-ports, it can be seen that *Netcruzer Ports* X5,X6,X7,X8,X9,Y6, Y7, Y8 and Y9 are available for all SBC66 board variants. Other ports can also be used, this is just an example!

6.4 When using iMod ports

If iMod modules are used, then the ports used by them can not be used for general purpose ports any more. To eliminate the ports used by these iMod modules, we recommend using the table at netcruzer.com/nzdoc-sbc66-ports. For example, if an [im232M](#) (RS-232) is used in iMod port 1, and [in485P](#) (RS-485) in iMod port 2, they will require the following 7 *Netcruzer Ports*: X1, X6, X7, X8, X9, Y8 and Y9.

- The im232M module (in iMod port 1) uses iMod ports 2,3,4 and 5. Looking at the table at netcruzer.com/nzdoc-sbc66-ports, we can see these ports use *Netcruzer Ports* **X1** (iMod 1-5), **X6** (iMod 1-4), **X7** (iMod 1-3) and **X8** (iMod 1-2).
- The in485P module (in iMod port 2) uses iMod ports 2,3 and 4. Looking at the table at netcruzer.com/nzdoc-sbc66-ports, we can see these ports use *Netcruzer Ports* **X9** (iMod 2-3), **Y8** (iMod 2-4) and **Y9** (iMod 2-2).

For this example, this will leave ports T4-T7, X2-X5, Y0-Y2, Y6,Y7 and Y11 available for most SBC66 board combinations.

7 Schematics

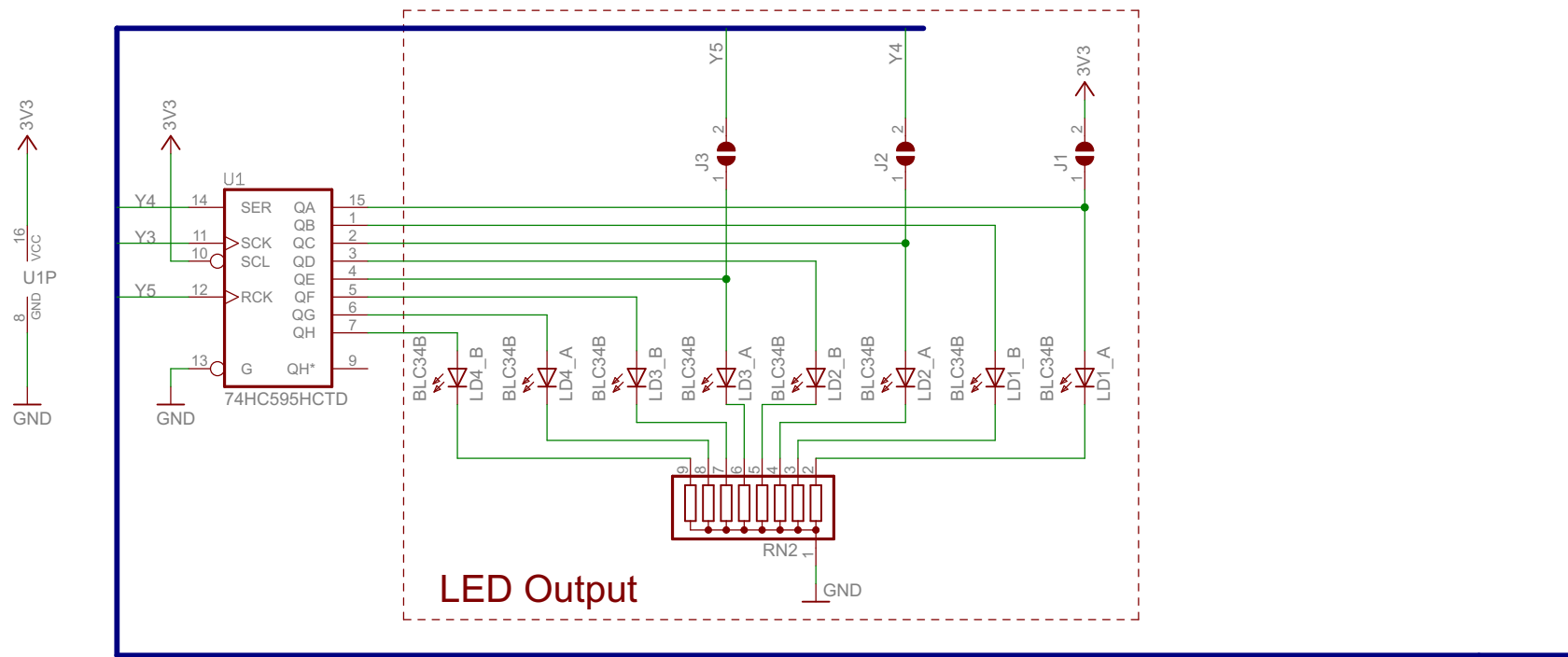

SC,SD,S[0..1],T[0..7],X[0..15],Y[0..14]

Procedure for writing values to LEDs

- Configure Y3 (clock), Y4 (serial data) and Y5 (latch) as outputs
- Clock out (clock pulse on Y3) all data for the serial/parallel shift registers on Y4
- Output a pulse (high-low-high) onto Y5. This will Latch serial data out of serial/parallel shift registers (on rising edge of clock)

Modtronix Engineering

TITLE: pt66eir1_doc

Document Number:

REU:

1

Date: 10/09/2012 11:20:07 AM

Sheet: 1/3

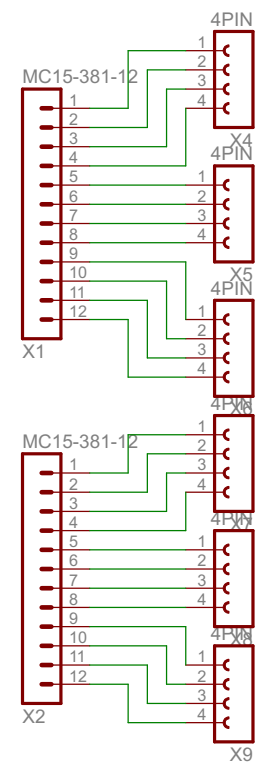
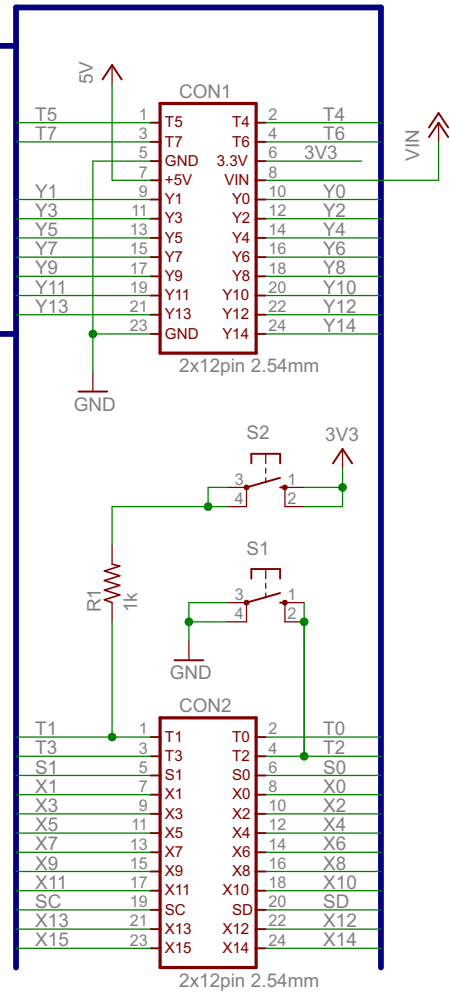
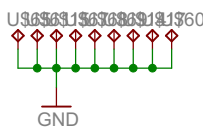
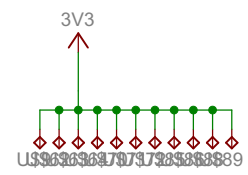
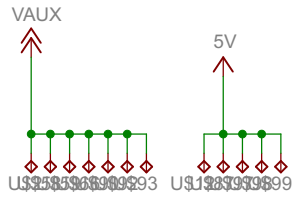
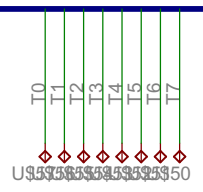
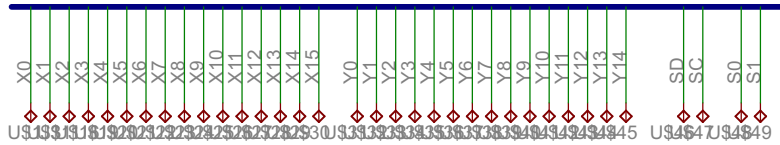

Modtronix Engineering	
TITLE: pt66eir1_doc	
Document Number:	REV: 1
Date: 10/09/2012 11:20:07 AM	Sheet: 2/3

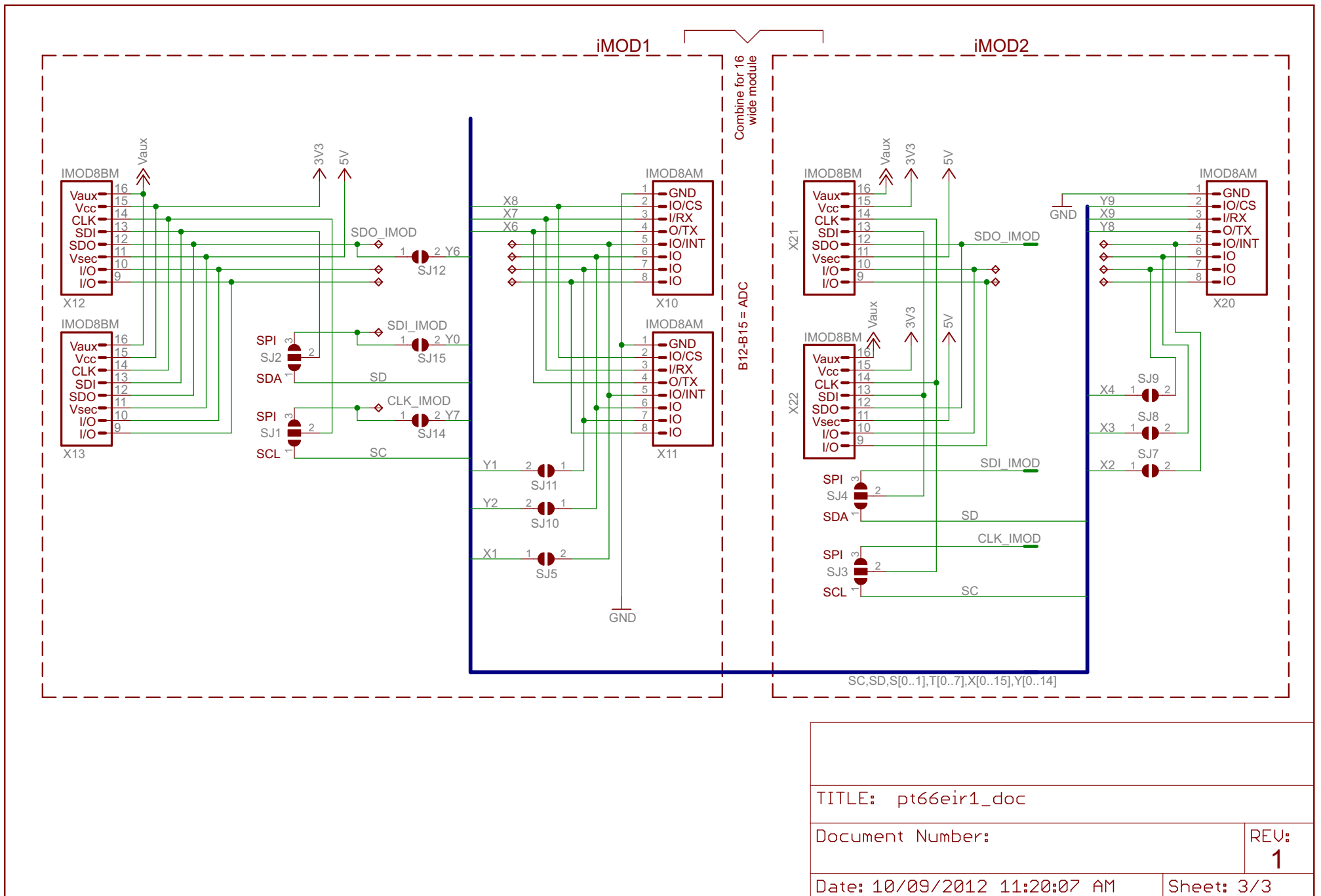

TITLE: pt66eir1_doc

Document Number:

REV:

1

Date: 10/09/2012 11:20:07 AM

Sheet: 3/3

Modtronix Engineering
www.modtronix.com

PT66EI REV1

These pins are unconnected for some daughter boards!

Align daughter board with these (end) pins!

3V iMOD1

iMOD2

3V3

